



STRONGBIZ MARKETING CORP.

Water System Supply Specialist

Email add: strongbiz.marketing@gmail.com

Telefax: 02 8358 4328 | 02 8355 0474 | 02 8251-1041

Website: www.strongbizmarketingcorp.com

Business Address: SBMC Building San Julian Malasiqui, Pangasinan

Sales Hotline: +639285211752 | +639125632464 | +639617537563

Water System Supply Specialist.

“ONE STOP SHOP”





STRONGBIZ MARKETING CORP.

Water System Supply Specialist

Email add: strongbiz.marketing@gmail.com

Telefax: 02 8358 4328 | 02 8355 0474 | 02 8251-1041

Website: www.strongbizmarketingcorp.com

Business Address: SBMC Building San Julian Malasiqui, Pangasinan

Sales Hotline: +639285211752 | +639125632464 | +639617537563



*“Water System Supply
Specialist”*

COMPANY PROFILE

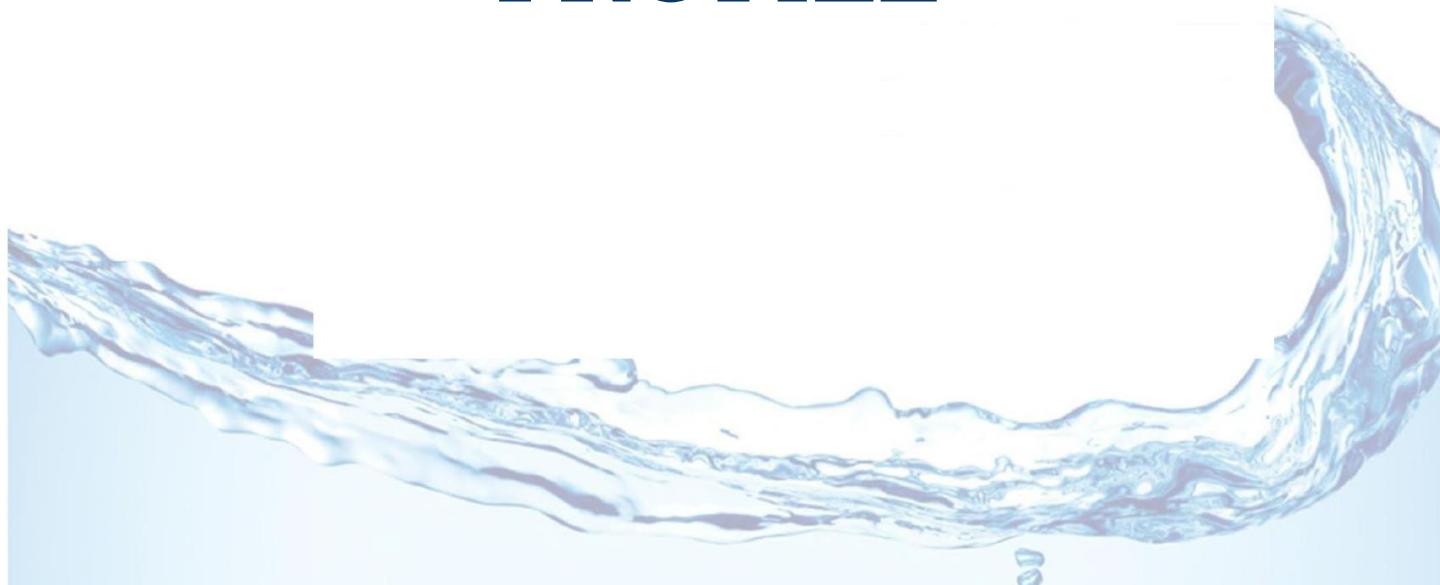



STRONGBIZ MARKETING CORP.

Water System Supply Specialist

Email add: strongbiz.marketing@gmail.com

Telefax: 02 8358 4328 | 02 8355 0474 | 02 8251-1041

Website: www.strongbizmarketingcorp.com

Business Address: SBMC Building San Julian Malasiqui, Pangasinan

Sales Hotline: +639285211752 | +639125632464 | +639617537563

TABLE OF CONTENTS

- 1. Historical Background**
- 2. Mission**
- 3. Vision**
- 4. Basic Information**
- 5. Organizational Chart**
- 6. Permits and Licenses**
- 7. Facilities**
- 8. Clients**
- 9. List of Projects**
- 10. Product Line**
- 11. Import Product Line**



STRONGBIZ MARKETING CORP.

Water System Supply Specialist

Email add: strongbiz.marketing@gmail.com

Telefax: 02 8358 4328 | 02 8355 0474 | 02 8251-1041

Website: www.strongbizmarketingcorp.com

Business Address: SBMC Building San Julian Malasiqui, Pangasinan

Sales Hotline: +639285211752 | +639125632464 | +639617537563

HISTORICAL BACKGROUND

2013

- SBMC has been established as a sole proprietorship.
- As a trading company of whom introduces the cast iron products like SCHIM and MECH GATE VALVES in the industry.

2015

- SBMC was registered as a corporate institution.

2017

- SBMC started to import products particularly in China and Thailand.



STRONGBIZ MARKETING CORP.

Water System Supply Specialist

Email add: strongbiz.marketing@gmail.com

Telefax: 02 8358 4328 | 02 8355 0474 | 02 8251-1041

Website: www.strongbizmarketingcorp.com

Business Address: SBMC Building San Julian Malasiqui, Pangasinan

Sales Hotline: +639285211752 | +639125632464 | +639617537563

MISSION

- To meet and maintain the highest standard and quality of services committed to clients to make them feel comfortable and confident working with our company.
- To meet target delivery schedules and deadlines in order not to delay the progress of work as perceived by the clients; and
- To wisely utilize materials, time and workforce in providing the clients with the highest quality of guaranteed materials.



STRONGBIZ MARKETING CORP.

Water System Supply Specialist

Email add: strongbiz.marketing@gmail.com

Telefax: 02 8358 4328 | 02 8355 0474 | 02 8251-1041

Website: www.strongbizmarketingcorp.com

Business Address: SBMC Building San Julian Malasiqui, Pangasinan

Sales Hotline: +630285211752 | +630125632464 | +630617537563

VISION

- We envision Strongbiz Marketing Corporation to be a multi-national marketing company that provides a complete supply solution and materials to all water service providers and the like.
- Strongbiz Marketing Corporation shall continue to co-exist as an able and reliable partner of the different public and private companies in meeting the growing demand not only on water industry but in different construction company in the country.

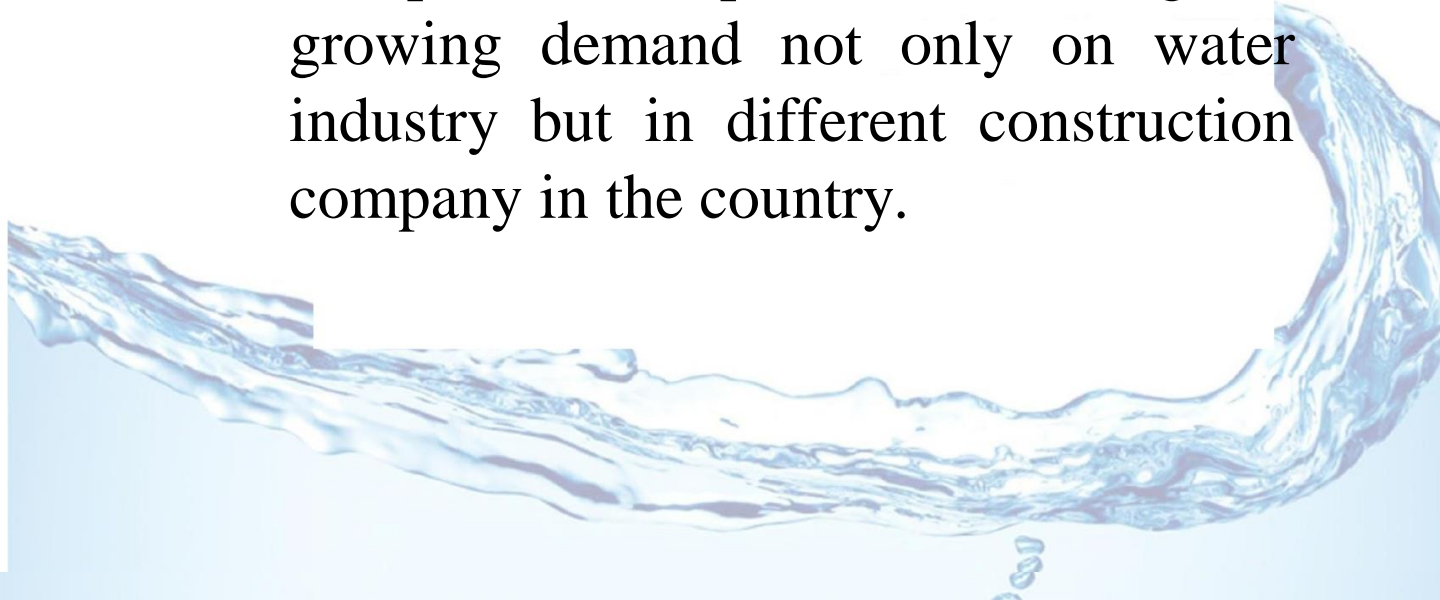



STRONGBIZ MARKETING CORP.

Water System Supply Specialist

Email add: strongbiz.marketing@gmail.com

Telefax: 02 8358 4328 | 02 8355 0474 | 02 8251-1041

Website: www.strongbizmarketingcorp.com

Business Address: SBMC Building San Julian Malasiqui, Pangasinan

Sales Hotline: +639285211751 | +639125831467 | +63967531503

BASIC INFORMATION

COMPANY NAME : **STRONGBIZ MARKETING CORPORATION**

ADDRESS : **BRGY. SAN JULIAN, MALASIQUI, PANGASINAN**

SEC REG. NO. : **CS201510018**

BIR TIN NO. : **009-046-273-000**

MAYOR'S PERMIT : **0315**

TELEPHONE NO. : **(802) 355-0474 / (075) 634-1852**

E-MAIL ADDRESS : **strongbiz.marketing@gmail.com
strongbiz.sales@gmail.com**

WEBSITE : **<https://strongbizmarketingcorp.com/>**

FAX NO. : **(802) 355-0474/(802) 355-0474/(802) 3584328**

DATE ESTABLISHED : **MAY 21, 2015**

BANK : **SECURITY BANK (Del Monte Branch)
BDO (Malasiqui Branch)
METROBANK (Bayambang Branch)
CHINABANK (Bayambang Branch)**



STRONGBIZ MARKETING CORP.

Water System Supply Specialist

Email add: strongbiz.marketing@gmail.com

Telefax: 02 8358 4328 | 02 8355 0474 | 02 8251-1041

Website: www.strongbizmarketingcorp.com

Business Address: SBMC Building San Julian Malasiqui, Pangasinan

Sales Hotline: +639285211752 | +639125632464 | +639617537563

STRONGBIZ MARKETING CORPORATION
maintains excellent banking relation along the following :



(Bayambang Branch)
0925-5285204



(Del Monte Branch)
0915-8792099



(Bayambang Branch)
147-50000-9404



(Malasiqui Branch)
367-1642 / 414-7373



STRONGBIZ MARKETING CORP.

Water System Supply Specialist

Email add: strongbiz.marketing@gmail.com

Telefax: 02 8358 4328 | 02 8355 0474 | 02 8251-1041

Website: www.strongbizmarketingcorp.com

Business Address: SBMC Building San Julian Malasiqui, Pangasinan

Sales Hotline: +639285211752 | +639125632464 | +639617537563

ORGANIZATION OFFICERS

GENERAL MANAGER	:	BOYET M. FRANCISCO
FINANCE MANAGER	:	VERONICA L. FRANCISCO
OPERATION MANAGER	:	SAQUER D. CAMBE
ACCOUNT OFFICER	:	JOYCE ANN PEREZ
	:	EDUARDO MENIL
SALES ASSISTANT	:	BLESSY FRANCISCO
PURCHASING HEAD	:	JOHN AUREO P. TAPIC
ACCOUNTING ASST.	:	RUSSEL MAMARIL
ACCOUNTS RECEIVABLE	:	ERICA PENOLIAR
BOOKKEEPER	:	MARY JANE MONDERO
INVENTORY ASST.	:	EDMARK GOROSPE
LOGISTIC HEAD	:	AL BATO
	:	FRANCIS FRANCISCO
LOGISTICS	:	RENATO W. SUDARIO
		RAYMUND C. UNTALAN
		ARNEL S. MAAMO
		JEROME M. REAL
		RONNIE M. SANICO
		WILVER LAZAGA



STRONGBIZ MARKETING CORP.

Water System Supply Specialist

Email add: strongbiz.marketing@gmail.com

Telefax: 02 8358 4328 | 02 8355 0474 | 02 8251-1041

Website: www.strongbizmarketingcorp.com

Business Address: SBMC Building San Julian Malasiqui, Pangasinan

Sales Hotline: +639285211752 | +639125632464 | +639617537563



PERMITS AND LICENCES



STRONGBIZ MARKETING CORP.

Water System Supply Specialist

Email add: strongbiz.marketing@gmail.com

Telefax: 02 8358 4328 | 02 8355 0474 | 02 8251-1041

Website: www.strongbizmarketingcorp.com

Business Address: SBMC Building San Julian Malasiqui, Pangasinan

Sales Hotline: +639285211752 | +639125632464 | +639617537563

SEC REGISTRATION



REPUBLIC OF THE PHILIPPINES
SECURITIES AND EXCHANGE COMMISSION
Ground Floor, Secretariat Building, PICC
City Of Pasay, Metro Manila

COMPANY REG. NO. CS201510018

CERTIFICATE OF FILING
OF
AMENDED ARTICLES OF INCORPORATION

KNOW ALL PERSONS BY THESE PRESENTS:

This is to certify that the amended articles of incorporation of the

STRONGBIZ MARKETING CORPORATION
(Amending Article III thereof)

copy annexed, adopted on December 09, 2021 by majority vote of the Board of Directors and by the vote of the stockholders owning or representing at least two-thirds of the outstanding capital stock, and certified under oath by the Corporate Secretary and a majority of the Board of Directors of the corporation was approved by the Commission on this date pursuant to the provision of Section 15 of the Revised Corporation Code of the Philippines, Republic Act No. 11232, which took effect on February 23, 2019, and copies thereof are filed with the Commission.

Unless this corporation obtains or already has obtained the appropriate Secondary License from this Commission, this Certificate does not authorize it to undertake business activities requiring a Secondary License from this Commission such as, but not limited to acting as: broker or dealer in securities, government securities eligible dealer (GSED), investment adviser of an investment company, close-end or open-end investment company, investment house, transfer agent, commodity/financial futures exchange/broker/merchant, financing/lending company and time shares/club shares/membership certificates issuers or selling agents thereof; nor to operate a fiat money to virtual currency exchange. Neither does this Certificate constitute as permit to undertake activities for which other government agencies require a license or permit.

IN WITNESS WHEREOF, I have set my hand and caused the seal of this Commission to be affixed to this Certificate at Pasay City, Metro Manila, Philippines, this 24th day of March, Twenty Twenty Two.

DANIEL P. GABUYO
Assistant Director
SO No. 1188 Series of 2018

SJ/qba



STRONGBIZ MARKETING CORP.

Water System Supply Specialist

Email add: strongbiz_marketing@gmail.com

Telefax: 02 8358 4328 | 02 8355 0474 | 02 8251-1041

Website: www.strongbizmarketingcorp.com

Business Address: SBMC Building San Julian Malasiqui, Pangasinan

Sales Hotline: +639285211752 | +639125632464 | +639617537563

CERTIFICATE OF REGISTRATION



001
004

ARC0001192815

009-046-273-002

STRONGBIZ MARKETING CORPORATION

05/18/2017

SAN JULIAN MALASIQUI
PANGASINAN 2421

TAX TYPE

REGISTRATION FEE

WITHHOLDING TAX - EXPANDED/OTH

TRADE NAME

LINE OF BUSINESS / INDUSTRY

STRONGBIZ MARKETING CORPORATIO

5190 OTHER WHOLESALING

REMINDERS:

Renewal of Annual Registration Fee is due on or before January 31, using BIR Form 0605.

Filing of required Tax Return/s to conform with the above registered tax types on or before due dates whether with or without operation, to avoid penalties and generation of Open Cases.

IMMEDIATELY inform this District Office in case of Transfer / Cessation or Closure of business and other concerns by filing BIR Form 1905 to stop generation of Open Cases.



Ma Bernadette B. Mangaoang
MA BERNADETTE B. MANGAOANG
Asst. Revenue District Officer

MERLYN DV. VICENTE
REVENUE DISTRICT OFFICER

Update
Date

Change In Registered Business Address :
06-13-2018



STRONGBIZ MARKETING CORP.

Water System Supply Specialist

Email add: strongbiz.marketing@gmail.com

Telefax: 02 8358 4328 | 02 8355 0474 | 02 8251-1041

Website: www.strongbizmarketingcorp.com

Business Address: SBMC Building San Julian Malasiqui, Pangasinan

Sales Hotline: +639285211752 | +639125632464 | +639617537563

MAYOR'S PERMIT

 Republic of the Philippines
MUNICIPALITY OF MALASIQUI
Province of Pangasinan

Office of the Mayor
BUSINESS PERMIT NO.: 315

TO WHOM IT MAY CONCERN:

PERMIT is hereby granted to
STRONGBIZ MARKETING CORPORATION

to operate a PLUMBING PARTS & MATERIALS & HARDWARE
at SBMC Bldg. 2nd Floor Brgy. San Julian,
Malasiqui, Pangasinan, subject to all existing laws, ordinances and
payment of required taxes, fees and dues.

This PERMIT may be cancelled anytime for false declarations, for
violations of laws and ordinances, and also when public interest so
demands.

Issued this 21st day of JANUARY, 20 22

Paid under O.R. No.: 4792867
Date: January 21, 2022
Amount Paid: ₱1,630.00
BAN NO. 22 - 00024

NON-TRANSFERABLE

REMINDER:
*Renew your license on or before January
20 of the ensuing year to avoid penalties.*

HON. NOEL ANTHONY M. GESLANI
MUNICIPAL MAYOR

NOTE:

- * Bring this PERMIT when renewing it for the incoming year.
- * When the business concern stops operations, this PERMIT must be surrendered to this Office for records purposes.
- * This PERMIT should be displayed in a conspicuous space where business operates.





STRONGBIZ MARKETING CORP.

Water System Supply Specialist

Email add: strongbiz.marketing@gmail.com

Telefax: 02 8358 4328 | 02 8355 0474 | 02 8251-1041

Website: www.strongbizmarketingcorp.com

Business Address: SBMC Building San Julian Malasiqui, Pangasinan

Sales Hotline: +639285211752 | +639125632464 | +639617537563

TAX CLEARANCE



REPUBLIC OF THE PHILIPPINES
DEPARTMENT OF FINANCE
BUREAU OF INTERNAL REVENUE
REVENUE REGION NO. 5 – CALOOCAN CITY
COLLECTION DIVISION

TCBP NO. RR5-027-07-28-R0829-2022-M

TAX CLEARANCE CERTIFICATE

(Pursuant to Executive Order No. 398)

STRONGBIZ MARKETING CORPORATION

Name of Taxpayer

6 SANTIAGO ST VISTA VERDE PUROK IV CAYBIGA BRGY 166 D1 CALOOCAN CITY

Address

009-046-273-000

Taxpayer Identification Number

This is to certify that the above mentioned taxpayer is eligible for issuance of this Tax Clearance Certificate having satisfied all the criteria set forth by the BIR as of the date of this certification pursuant to Revenue Regulations No. 8-2016, as amended.

Tax liabilities recorded after the aforesaid dates or outside the jurisdiction of this Office are not covered by this tax clearance.

Issued this 28th day of July 2022.

NOTE: THIS CERTIFICATE SHALL BE VALID AND EFFECTIVE FROM DATE OF ISSUE UNTIL JULY 28, 2023 ONLY OR UNTIL REVOKED FOR VIOLATION OF THE CRITERIA SPECIFIED UNDER REVENUE REGULATIONS NO. 8-2016, AS AMENDED AND REVENUE MEMORANDUM ORDER NO. 46-2018, WHICHEVER COMES EARLIER. THIS SHALL NOT BE USED ON SALES/TRANSFER OF REAL PROPERTIES. CERTIFICATION FEE OF P100 WAS PAID ON JULY 26, 2022 THRU EPFS PAYMENT TRANSACTION NO. 228967308. ANY ERASURE MADE ON THIS TCC SHALL RENDER IT NULL AND VOID.



ROBERTO R. TARON
Chief, Collection Division



WARNING: Counterfeiting is punishable by law. For authenticity, please visit BIR website www.bir.gov.ph/index.php/tax-clearance/released-tax-clearance.html. Tax Clearance Certificate (for bidding purposes) not listed/posted herein will be deemed to have originated from an illegal source.



STRONGBIZ MARKETING CORP.

Water System Supply Specialist

Email add: strongbiz.marketing@gmail.com

Telefax: 02 8358 4328 | 02 8355 0474 | 02 8251-1041

Website: www.strongbizmarketingcorp.com

Business Address: SBMC Building San Julian Malasiqui, Pangasinan

Sales Hotline: +639285211752 | +639125632464 | +639617537563

LWUA ACCREDITATION



Republic of the Philippines

**LOCAL
WATER
UTILITIES
ADMINISTRATION**

CERTIFICATE OF ACCREDITATION

No. 732S-2017

This is to certify that

STRONGBIZ MARKETING CORPORATION

With office address at : **#6 Santiago Street, Vista Verde
North Executive Village,
Brgy. Caybiga, Caloocan City**

Is an accredited supplier of :

**"XD Ever" 15mm ø Class B Water Meter
"Flowsystem" "EV-Jet" 15 mm ø Class B Water Meter
"Concord" CI Valve/Fittings/Fire Hydrants
"Goodyear Steel Pipe Corp" uPVC Pipes/ HDPE/BI/GI/Steel Pipes**

This accreditation is non-transferable, is subject to cancellation, revocation, and surrender upon demand at any time after due deliberation and proper advice by the Local Water Utilities Administration.

Issued 25 September 2017 at LWUA, Katipunan Road, Balara, Quezon City and will expire on 24 September 2018.

Recommending Approval:

ALFREDO G. BAYANIN
Chairman
Technical Standards Committee

Approved:

JECI A. LAPUS
Acting Administrator



STRONGBIZ MARKETING CORP.

Water System Supply Specialist

Email add: strongbiz.marketing@gmail.com

Telefax: 02 8358 4328 | 02 8355 0474 | 02 8251-1041

Website: www.strongbizmarketingcorp.com

Business Address: SBMC Building San Julian Malasiqui, Pangasinan

Sales Hotline: +639285211752 | +639125632464 | +639617537563

PHILGEPS REGISTRATION

Republic of the Philippines
Department of Budget and Management
PROCUREMENT SERVICE

CERTIFICATE OF PHILGEPS REGISTRATION (Platinum Membership)

THIS IS TO CERTIFY THAT

STRONGBIZ MARKETING CORPORATION

117 SAN JULIAN ,
Malasiqui , Pangasinan , Region I , Philippines

is registered in the **Philippine Government Electronic Procurement System (PhilGEPS)** on **24-Sep-2015** pursuant to Section 8.5.2 of the Revised Implementing Rules and Regulations of Republic Act No. 9184, otherwise known as the Government Procurement Reform Act.

This further certifies that **STRONGBIZ MARKETING CORPORATION** has submitted the required eligibility documents in the PhilGEPS Supplier Registry as listed in Annex A, which document is attached hereto and made an integral part hereof.

For the purpose of updating this Certificate, all Class "A" eligibility documents covered by Section 8.5.2 of the Revised Implementing Rules and Regulations of Republic Act No. 9184 supporting the veracity, authenticity and validity of this Certificate shall remain current and updated. The failure by the prospective Bidder to update this Certificate with the current and updated Class "A" eligibility documents shall result in the automatic suspension of its validity until such time that all of the expired Class "A" eligibility documents has been updated.

By submitting this Certificate, the Bidder certifies:

1. the authenticity, genuineness, validity, and completeness of the copy of the original eligibility documents submitted;
2. the veracity of the statements and information contained therein;
3. that the Certificate is not a guaranty that the named registrant will be declared eligible without first being determined to be such for that particular bidding, nor is it an evidence that the Bidder has passed the post-qualification stage; and
4. that any finding of concealment, falsification, or misrepresentation of any of the eligibility documents submitted, or the contents thereof shall be a ground for disqualification from further participation in the bidding process, without prejudice to the imposition of appropriate administrative, civil and criminal penalty in accordance with the laws.

This Certificate is valid until 04-Aug-2023

Issued this 03rd day of August 2022.

This is a system generated certificate. No signature is required.



Documentary Stamp Tax Paid Php 30.00
Certificate Reference No: 201509149402916706305
Amended Date as of August 16, 2022 3:04 PM



STRONGBIZ MARKETING CORP.

Water System Supply Specialist

Email add: strongbiz.marketing@gmail.com

Telefax: 02 8358 4328 | 02 8355 0474 | 02 8251-1041

Website: www.strongbizmarketingcorp.com

Business Address: SBMC Building San Julian Malasiqui, Pangasinan

Sales Hotline: +639285211752 | +639125632464 | +639617537563



FACILITIES





STRONGBIZ MARKETING CORP.

Water System Supply Specialist

Email add: strongbiz.marketing@gmail.com

Telefax: 02 8358 4328 | 02 8355 0474 | 02 8251-1041

Website: www.strongbizmarketingcorp.com

Business Address: SBMC Building San Julian Malasiqui, Pangasinan

Sales Hotline: +639285211752 | +639125632464 | +639617537563

SBMC MAIN



**LOCATED AT BARANGAY SAN JULIAN, MALASIQUI,
PANGASINAN**





STRONGBIZ MARKETING CORP.

Water System Supply Specialist

Email add: strongbiz.marketing@gmail.com

Telefax: 02 8358 4328 | 02 8355 0474 | 02 8251-1041

Website: www.strongbizmarketingcorp.com

Business Address: SBMC Building San Julian Malasiqui, Pangasinan

Sales Hotline: +639285211752 | +639125632464 | +639617537563

OFFICES

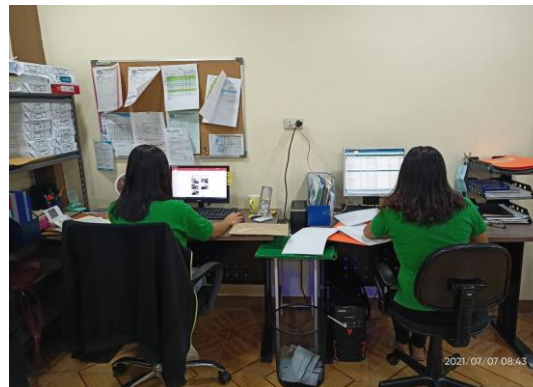
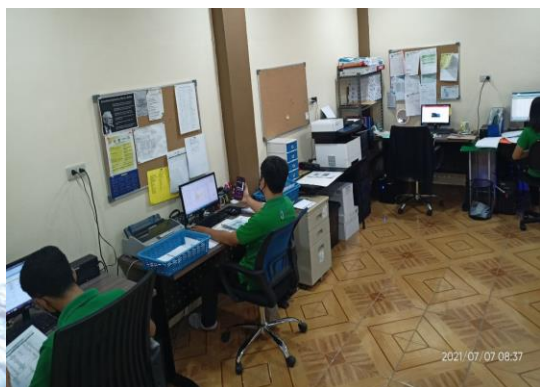



STRONGBIZ MARKETING CORP.

Water System Supply Specialist

Email add: strongbiz.marketing@gmail.com

Telefax: 02 8358 4328 | 02 8355 0474 | 02 8251-1041

Website: www.strongbizmarketingcorp.com

Business Address: SBMC Building San Julian Malasiqui, Pangasinan

Sales Hotline: +639285211752 | +639125632464 | +639617537563

STOCKROOMS





STRONGBIZ MARKETING CORP.

Water System Supply Specialist

Email add: strongbiz.marketing@gmail.com

Telefax: 02 8358 4328 | 02 8355 0474 | 02 8251-1041

Website: www.strongbizmarketingcorp.com

Business Address: SBMC Building San Julian Malasiqui, Pangasinan

Sales Hotline: +639285211752 | +639125632464 | +639617537563

STOCK ROOMS





STRONGBIZ MARKETING CORP.

Water System Supply Specialist

Email add: strongbiz.marketing@gmail.com

Telefax: 02 8358 4328 | 02 8355 0474 | 02 8251-1041

Website: www.strongbizmarketingcorp.com

Business Address: SBMC Building San Julian Malasiqui, Pangasinan

Sales Hotline: +639285211752 | +639125632464 | +639617537563

SBMC WORKFORCE





STRONGBIZ MARKETING CORP.

Water System Supply Specialist

Email add: strongbiz.marketing@gmail.com

Telefax: 02 8358 4328 | 02 8355 0474 | 02 8251-1041

Website: www.strongbizmarketingcorp.com

Business Address: SBMC Building San Julian Malasiqui, Pangasinan

Sales Hotline: +639285211752 | +639125632464 | +639617537563

CLIENTS





STRONGBIZ MARKETING CORP.

Water System Supply Specialist

Email add: strongbiz.marketing@gmail.com

Telefax: 02 8358 4328 | 02 8355 0474 | 02 8251-1041

Website: www.strongbizmarketingcorp.com

Business Address: SBMC Building San Julian Malasiqui, Pangasinan

Sales Hotline: +639285211752 | +639125632464 | +639617537563

GOVERNMENT



San Jose City Water District
San Jose City, Nueva Ecija



STRONGBIZ MARKETING CORP.

Water System Supply Specialist

Email add: strongbiz.marketing@gmail.com

Telefax: 02 8358 4328 | 02 8355 0474 | 02 8251-1041

Website: www.strongbizmarketingcorp.com

Business Address: SBMC Building San Julian Malasiqui, Pangasinan

Sales Hotline: +639285211752 | +639125632464 | +639617537563

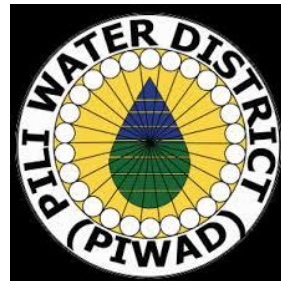



STRONGBIZ MARKETING CORP.

Water System Supply Specialist

Email add: strongbiz.marketing@gmail.com

Telefax: 02 8358 4328 | 02 8355 0474 | 02 8251-1041

Website: www.strongbizmarketingcorp.com

Business Address: SBMC Building San Julian Malasiqui, Pangasinan

Sales Hotline: +639285211752 | +639125632464 | +639617537563

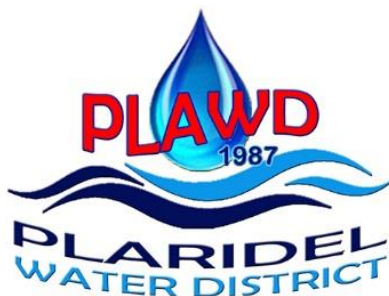

Taysan Water District

I.G. Sulit Sr. St Poblacion East

Taysan Batangas



STRONGBIZ MARKETING CORP.

Water System Supply Specialist

Email add: strongbiz.marketing@gmail.com

Telefax: 02 8358 4328 | 02 8355 0474 | 02 8251-1041

Website: www.strongbizmarketingcorp.com

Business Address: SBMC Building San Julian Malasiqui, Pangasinan

Sales Hotline: +639285211752 | +639125632464 | +639617537563

PRIVATE





STRONGBIZ MARKETING CORP.

Water System Supply Specialist

Email add: strongbiz.marketing@gmail.com

Telefax: 02 8358 4328 | 02 8355 0474 | 02 8251-1041

Website: www.strongbizmarketingcorp.com

Business Address: SBMC Building San Julian Malasiqui, Pangasinan

Sales Hotline: +639285211752 | +639125632464 | +639617537563



LIST OF PROJECTS





STRONGBIZ MARKETING CORP.

Water System Supply Specialist

Email add: strongbiz.marketing@gmail.com

Telefax: 02 8358 4328 | 02 8355 0474 | 02 8251-1041

Website: www.strongbizmarketingcorp.com

Business Address: SBMC Building San Julian Malasiqui, Pangasinan

Sales Hotline: +639285211752 | +639125632464 | +639617537563



MALASIQUI WATER SYSTEM

(Malasiqui, Pangasinan)

2018



STRONGBIZ MARKETING CORP.

Water System Supply Specialist

Email add: strongbiz.marketing@gmail.com

Telefax: 02 8358 4328 | 02 8355 0474 | 02 8251-1041

Website: www.strongbizmarketingcorp.com

Business Address: SBMC Building San Julian Malasiqui, Pangasinan

Sales Hotline: +639285211752 | +639125632464 | +639617537563



DPWH R1 Bauang Water System

(Acao, Bauang, La Union)

2017



STRONGBIZ MARKETING CORP.

Water System Supply Specialist

Email add: strongbiz.marketing@gmail.com

Telefax: 02 8358 4328 | 02 8355 0474 | 02 8251-1041

Website: www.strongbizmarketingcorp.com

Business Address: SBMC Building San Julian Malasiqui, Pangasinan

Sales Hotline: +639285211752 | +639125632464 | +639617537563



ALWASA WATER FILTRATION SYSTEM

(Alfonso Lista, Ifugao Province)

2013-2018



STRONGBIZ MARKETING CORP.

Water System Supply Specialist

Email add: strongbiz.marketing@gmail.com

Telefax: 02 8358 4328 | 02 8355 0474 | 02 8251-1041

Website: www.strongbizmarketingcorp.com

Business Address: SBMC Building San Julian Malasiqui, Pangasinan

Sales Hotline: +639285211752 | +639125632464 | +639617537563



PRODUCT LINE





STRONGBIZ MARKETING CORP.

Water System Supply Specialist

Email add: strongbiz.marketing@gmail.com

Telefax: 02 8358 4328 | 02 8355 0474 | 02 8251-1041

Website: www.strongbizmarketingcorp.com

Business Address: SBMC Building San Julian Malasiqui, Pangasinan

Sales Hotline: +639285211752 | +639125632464 | +639617537563

UPVC PIPES AND FITTINGS





STRONGBIZ MARKETING CORP.

Water System Supply Specialist

Email add: strongbiz.marketing@gmail.com

Telefax: 02 8358 4328 | 02 8355 0474 | 02 8251-1041

Website: www.strongbizmarketingcorp.com

Business Address: SBMC Building San Julian Malasiqui, Pangasinan

Sales Hotline: +639285211752 | +639125632464 | +639617537563

PE PIPES AND FITTINGS



- | | | |
|---|---|---|
|  |  |  |
| 7001 Coupling | 7002 Reducing Coupling | 7003 Female Coupling |
|  |  |  |
| 7004 Male Coupling | 7005 End Cap | 7006 Elbow |
|  |  |  |
| 7007 Male Elbow | 7008 Female Elbow | 7009 Equal Tee |
|  |  |  |
| 7010 Female Tee | 7011 Male Tee | 7012 Reducing Tee |



STRONGBIZ MARKETING CORP.

Water System Supply Specialist

Email add: strongbiz.marketing@gmail.com

Telefax: 02 8358 4328 | 02 8355 0474 | 02 8251-1041

Website: www.strongbizmarketingcorp.com

Business Address: SBMC Building San Julian Malasiqui, Pangasinan

Sales Hotline: +639285211752 | +639125632464 | +639617537563

WATER METERS & FLOWMETERS





STRONGBIZ MARKETING CORP.

Water System Supply Specialist

Email add: strongbiz.marketing@gmail.com

Telefax: 02 8358 4328 | 02 8355 0474 | 02 8251-1041

Website: www.strongbizmarketingcorp.com

Business Address: SBMC Building San Julian Malasiqui, Pangasinan

Sales Hotline: +639285211752 | +639125632464 | +639617537563

BRASS FITTINGS





STRONGBIZ MARKETING CORP.

Water System Supply Specialist

Email add: strongbiz.marketing@gmail.com

Telefax: 02 8358 4328 | 02 8355 0474 | 02 8251-1041

Website: www.strongbizmarketingcorp.com

Business Address: SBMC Building San Julian Malasiqui, Pangasinan

Sales Hotline: +639285211752 | +639125632464 | +639617537563

G.I/B.I PIPES AND FITTINGS





STRONGBIZ MARKETING CORP.

Water System Supply Specialist

Email add: strongbiz.marketing@gmail.com

Telefax: 02 8358 4328 | 02 8355 0474 | 02 8251-1041

Website: www.strongbizmarketingcorp.com

Business Address: SBMC Building San Julian Malasiqui, Pangasinan

Sales Hotline: +639285211752 | +639125632464 | +639617537563

VALVES AND FIRE HYDRANTS





STRONGBIZ MARKETING CORP.

Water System Supply Specialist

Email add: strongbiz.marketing@gmail.com

Telefax: 02 8358 4328 | 02 8355 0474 | 02 8251-1041

Website: www.strongbizmarketingcorp.com

Business Address: SBMC Building San Julian Malasiqui, Pangasinan

Sales Hotline: +639285211752 | +639125632464 | +639617537563

CAST IRON FITTINGS





STRONGBIZ MARKETING CORP.

Water System Supply Specialist

Email add: strongbiz.marketing@gmail.com

Telefax: 02 8358 4328 | 02 8355 0474 | 02 8251-1041

Website: www.strongbizmarketingcorp.com

Business Address: SBMC Building San Julian Malasiqui, Pangasinan

Sales Hotline: +639285211752 | +639125632464 | +639617537563

PUMP AND MOTORS





STRONGBIZ MARKETING CORP.

Water System Supply Specialist

Email add: strongbiz.marketing@gmail.com

Telefax: 02 8358 4328 | 02 8355 0474 | 02 8251-1041

Website: www.strongbizmarketingcorp.com

Business Address: SBMC Building San Julian Malasiqui, Pangasinan

Sales Hotline: +639285211752 | +639125632464 | +639617537563

TEFLON AND WARNING TAPES





STRONGBIZ MARKETING CORP.

Water System Supply Specialist

Email add: strongbiz.marketing@gmail.com

Telefax: 02 8358 4328 | 02 8355 0474 | 02 8251-1041

Website: www.strongbizmarketingcorp.com

Business Address: SBMC Building San Julian Malasiqui, Pangasinan

Sales Hotline: +639285211752 | +639125632464 | +639617537563

CHLORINATOR & CHLORINE GRANULES





STRONGBIZ MARKETING CORP.

Water System Supply Specialist

Email add: strongbiz.marketing@gmail.com

Telefax: 02 8358 4328 | 02 8355 0474 | 02 8251-1041

Website: www.strongbizmarketingcorp.com

Business Address: SBMC Building San Julian Malasiqui, Pangasinan

Sales Hotline: +639285211752 | +639125632464 | +639617537563

IMPORT PRODUCT LINE





STRONGBIZ MARKETING CORP.

Water System Supply Specialist

Email add: strongbiz.marketing@gmail.com

Telefax: 02 8358 4328 | 02 8355 0474 | 02 8251-1041

Website: www.strongbizmarketingcorp.com

Business Address: SBMC Building San Julian Malasiqui, Pangasinan

Sales Hotline: +639285211752 | +639125632464 | +639617537563

LL 1291 Ball Valve with Lockwing

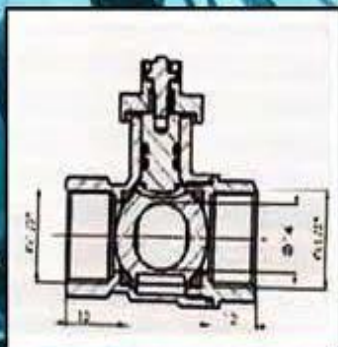

WORKING PRESSURE:

PN 25

SIZES:

DN 15 / 20 / 25

MATERIAL:

BRASS

WORKING TEMP.:

-10°C to 120°C

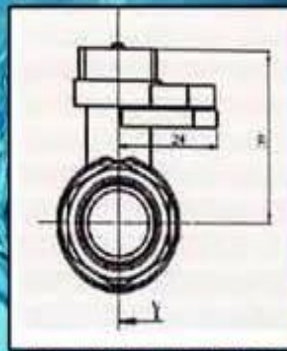
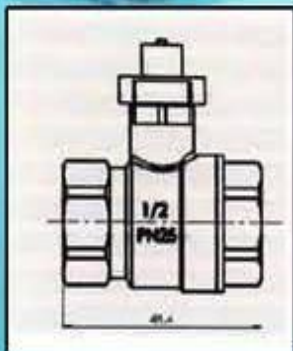

Features:

Standard Line / Full Bore

Perfect Seal

Wear Resistant, solid and durable

Anti Blow-Out Stem

Head Pin Lock Permanently connected to stem



STRONGBIZ MARKETING CORP.

Water System Supply Specialist

Email add: strongbiz_marketing@gmail.com

Telefax: 02 8358 4328 | 02 8355 0474 | 02 8251-1041

Website: www.strongbizmarketingcorp.com

Business Address: SBMC Building San Julian Malasiqui, Pangasinan

Sales Hotline: +639285211752 | +639125632464 | +639617537563

AWWA C515 Flanged Resilient NRS Gate Valve (Z45X), NSF Approved



Z45X
NSFANSI 61 NSFANSI 372

- Connection Ends: Flange to ASME B16.1 CL 125
- Working Pressure: 300PSI
200PSI and 250PSI available upon request
- Temperature Range: 0°C - 80°C
- Coating: Fusion Bonded Epoxy Coating in accordance with ANSI/AWWA C550



Z45XC

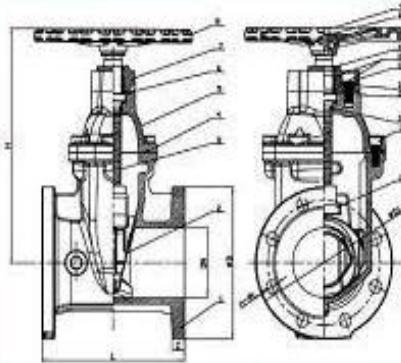

MATERIAL SPECIFICATION

Part No.	Part	Standard Specification	Options
1	Valve Body	ASTM A536, 65-45-12	
2	Resilient Wedge Disc	ASTM A536, 65-45-12-EPDM	
3	Stem	AISI 431	AISI 304, AISI 316, AISI 428, AL-bronze
4	Bonnet Gasket	EPDM	NER
5	Bonnet	ASTM A536, 65-45-12	
6	O-Ring	NER	EPDM
7	Gland	ASTM A536, 65-45-12	
8	Handwheel	ASTM A536, 65-45-12	Pressed Steel
9	Bolt	Carbon Steel Zinc Plated	AISI 304, AISI 316
10	Flat Washer	Carbon Steel Zinc Plated	AISI 304, AISI 316
11	Ring Nipper	EPDM	NER
12	O-Ring	NER	EPDM
13	Nut	Carbon Steel Zinc Plated	AISI 304, AISI 316
14	Axis Guide	Brass 19620-1	
15	Washer	Brass 19620-1	
16	O-Ring	NER	EPDM
17	Nut	Carbon Steel Zinc Plated	AISI 304, AISI 316
18	Wedge Nut	Brass 19620-1	Brass D2545-5-5

Note: For special material request other than standard specification, please indicate clearly on the inquiry or order list.

DN		Dimensions (mm)						
Inch	mm	L	H	D	D1	C	n-ØL	
2"	50	178	254	152	120.7	18	4-Ø18.1	
2.5"	65	196	275	178	139.7	17.5	4-Ø18.1	
3"	80	203	301	191	152.4	18.1	4-Ø18.1	
4"	100	228	355	225	190.5	19.1	8-Ø18.1	
5"	125	254	393	254	215.8	19.1	8-Ø22.2	
6"	150	267	448	278	241.3	19.1	8-Ø22.2	
6"	200	292	548	343	298.5	22.2	8-Ø22.2	
10"	250	332	628	408	302	23.8	12-Ø25.4	
12"	300	358	722	483	431.8	25.4	12-Ø25.4	
14"	350	381	847	533	478.25	30.65	12-Ø28.6	
16"	400	408	917	597	528.75	30.68	16-Ø28.6	
18"	450	432	1108	656	577.85	30.62	16-Ø31.8	
20"	500	457	1130	688	635.00	42.93	20-Ø31.8	
24"	600	508	1311	813	749.3	47.75	20-Ø34.9	



STRONGBIZ MARKETING CORP.

Water System Supply Specialist

Email add: strongbiz.marketing@gmail.com

Telefax: 02 8358 4328 | 02 8355 0474 | 02 8251-1041

Website: www.strongbizmarketingcorp.com

Business Address: SBMC Building San Julian Malasiqui, Pangasinan

Sales Hotline: +639285211752 | +639125632464 | +639617537563

UNIVERSAL D.I. Sleeve Type / Repair COUPLING

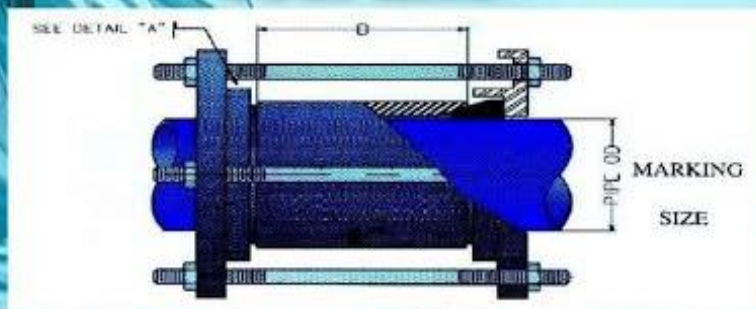

SIZE	PIPE OD mm PVC	T	Lenght B mm
50	63	10	275
75	90	12	275
100	110	13	275
150	160	14	275
200	225	15.2	275





STRONGBIZ MARKETING CORP.

Water System Supply Specialist

Email add: strongbiz.marketing@gmail.com

Telefax: 02 8358 4328 | 02 8355 0474 | 02 8251-1041

Website: www.strongbizmarketingcorp.com

Business Address: SBMC Building San Julian Malasiqui, Pangasinan

Sales Hotline: +639285211752 | +639125632464 | +639617537563



PB PIPE (THAILAND) CO., LTD



COMPRESSION

"NON-LOOSE COMPONENT"



HIGH PERFORMANCE, EASY JOINTING, NON TOXIC

HIGH CHEMICAL RESISTANCE, VERSATILITY

PN16

COMPATIBLE WITH HDPE PIPES

PRODUCED IN ACCORDANCE WITH ISO 4427

MADE IN THAILAND



STRONGBIZ MARKETING CORP.

Water System Supply Specialist

Email add: strongbiz.marketing@gmail.com

Telefax: 02 8358 4328 | 02 8355 0474 | 02 8251-1041

Website: www.strongbizmarketingcorp.com

Business Address: SBMC Building San Julian Malasiqui, Pangasinan

Sales Hotline: +639285211752 | +639125632464 | +639617537563



The Ideal fittings

PUSHON

An Innovative Ideal Fittings for HDPE Pipes



Compact Design, Full Flow, Easy Installation & Maintenance,

Non-corrosive, Excellent UV Resistance,

Leak proof with "EPDM" synthetic rubber seal,

Non-removable without release key



PN16



ISO 17885 : 2015
Made In Thailand



STRONGBIZ MARKETING CORP.

Water System Supply Specialist

Email add: strongbiz.marketing@gmail.com

Telefax: 02 8358 4328 | 02 8355 0474 | 02 8251-1041

Website: www.strongbizmarketingcorp.com

Business Address: SBMC Building San Julian Malasiqui, Pangasinan

Sales Hotline: +639285211752 | +639125632464 | +639617537563



THE ACCURACY COUNTS



PLASTIC WATER METER MODEL MAM-P

- Bi-directional Type
- "ABS" Plastic Body with Glass Fiber Reinforced
- Impact Resistance, Toughness, Rigidity
- With Bronze Thread Inlet / Outlet



Dry Dial Plastic Body Water Meter

ISO 4064, R50

Made In Thailand



STRONGBIZ MARKETING CORP.

Water System Supply Specialist

Email add: strongbiz.marketing@gmail.com

Telefax: 02 8358 4328 | 02 8355 0474 | 02 8251-1041

Website: www.strongbizmarketingcorp.com

Business Address: SBMC Building San Julian Malasiqui, Pangasinan

Sales Hotline: +639285211752 | +639125632464 | +639617537563



THE ACCURACY COUNTS



WATER METER MODEL MAM-P

Dry Dial Plastic Body Water Meter

MAM-P Dry Dial Plastic Body Water Meter is a vane wheel, multi-jet type water meter with a separate measuring chamber.

Within this Plastic meter case, there are two primary elements, the hermetically sealed register and the measuring chamber.

The vane wheel is revolved by jet streams passing through specially shaped inlet nozzles of the measuring chamber and the motion of the vane wheel is transmitted to the hermetically sealed register by a magnetic couple buried in the vane wheel spindle and the register.

This TAC water meter is superior not only in accurate measurement from starting flow to maximum flow, but also in durability.

Besides certification from Thai Industrial Standard : ISO 4064, we are also awarded ISO 9001:2015 certificate.

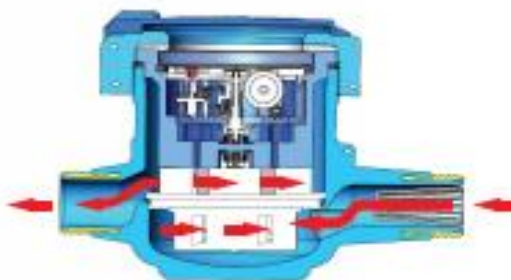

DESIGN FEATURES

1. Specially Shaped Inlet Nozzles and Light Weight Vane Wheel : Ensures a constant high accuracy for a wide flow range.
2. Selected Synthetic Material : Resistant to corrosion and long working life.
3. Hermetically Sealed Register : Permanent clear view.
4. Magnetic Drive : High accuracy of low flow and high durability by eliminating a gland or a stuffing box.
5. Magnet Shielding : High quality of protection against external magnetic field.





STRONGBIZ MARKETING CORP.

Water System Supply Specialist

Email add: strongbiz.marketing@gmail.com

Telefax: 02 8358 4328 | 02 8355 0474 | 02 8251-1041

Website: www.strongbizmarketingcorp.com

Business Address: SBMC Building San Julian Malasiqui, Pangasinan

Sales Hotline: +639285211752 | +639125632464 | +639617537563

AUTOMATIC AIR RELEASE VALVES



Air Valves

Double Effect (Automatic)

1/2" - 3/4" - 1" Double Effect (Automatic) Air Valve (PN10 - 16)

#	Material Name	Feature
1	Body	Glass Reinforced polyamide
2	O-Ring	NBR
3	Float	Polipropilen
4	Cover	Glass Reinforced polyamide
5	Float Tire	EPDM

#	Unit	1/2"	3/4"	1"
H	Height (mm)	112	112,75	136,57
W	Width (mm)	58,88	58,88	85,65
D	Connection Diameter	1/2"BSP	3/4"BSP	1"BSP
A	Evacuation Mouthpiece	25mm ²	25mm ²	25mm ²
-	Weight (kg)	0,140	0,141	0,304

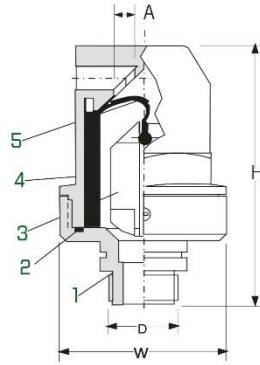



STRONGBIZ MARKETING CORP.

Water System Supply Specialist

Email add: strongbiz.marketing@gmail.com

Telefax: 02 8358 4328 | 02 8355 0474 | 02 8251-1041

Website: www.strongbizmarketingcorp.com

Business Address: SBMC Building San Julian Malasiqui, Pangasinan

Sales Hotline: +639285211752 | +639125632464 | +639617537563

WHY CHOOSE OUR PRODUCTS???

- **HIGH QUALITY PRODUCTS
(ISO CERTIFIED)**
- **ADDED SECURITY FEATURES
(LOCKS, SEALED, ANTI -TAMPER AND KEY
TO DISMANTLE)**
- **FINANCIALLY FEASIBLE**

(NRW) (%)

- 1. LEAKAGES (leak detectors / repair clamps)**
- 2. THEFT**
- 3. WATER METER ACCURACY (6 -8 l/h)**

(e.g.)

READING:

**MOTHER METER) = water meters (no. of customers)
(FLOWMETER)**

100,000 cu. m

= 80,000 cu. m

difference

= 20,000 cu. M (20% NRW)

@20/cu.m Php. 2M

= Php. 400,000.00 loss